

BUTLER

SPECIALTY COMPANY

EST. 1930

Assembly Instructions
5769497, 5769498 & 5770497, 5770498
King Bed & Queen Bed

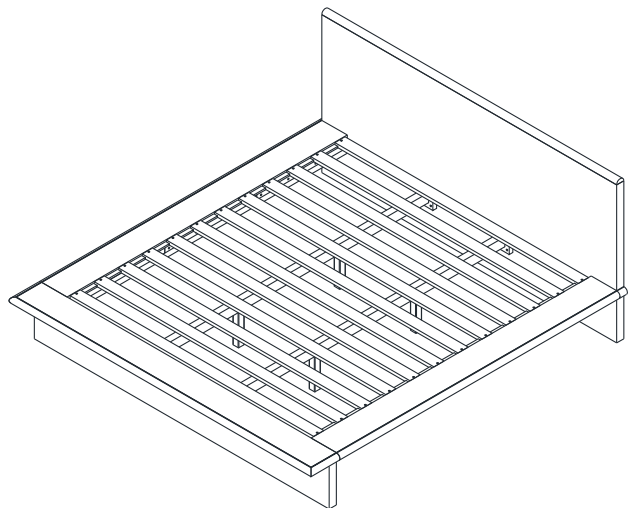
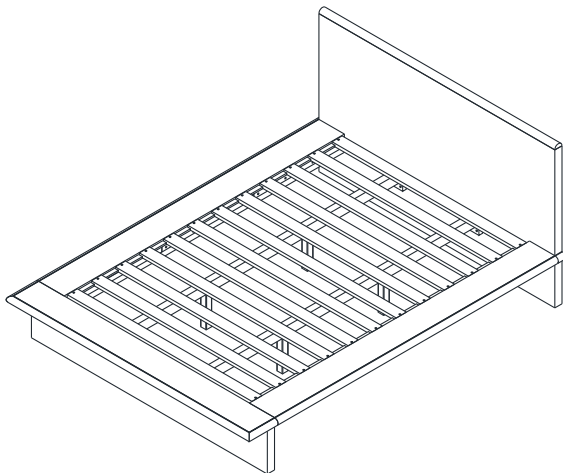

ITEM	DESCRIPTION	QUANTITY
A	Headboard	1
B	Footboard	1
C	Rails	2
D	Center Support	2
E	Center Legs	4
F	Slats	12
G	Bolt M8 x 100 mm	8
H	Halfmoon Washer	8
I	Nut M8 x 12 mm	8
J	Allen Wrench 12 mm	1
K	Screw JF 8 x 1"	24
L	Screw Driver (Not Include)	

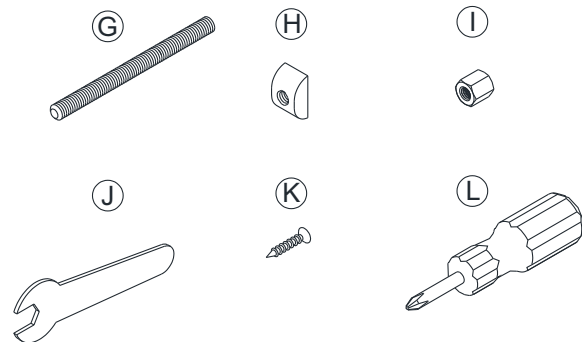
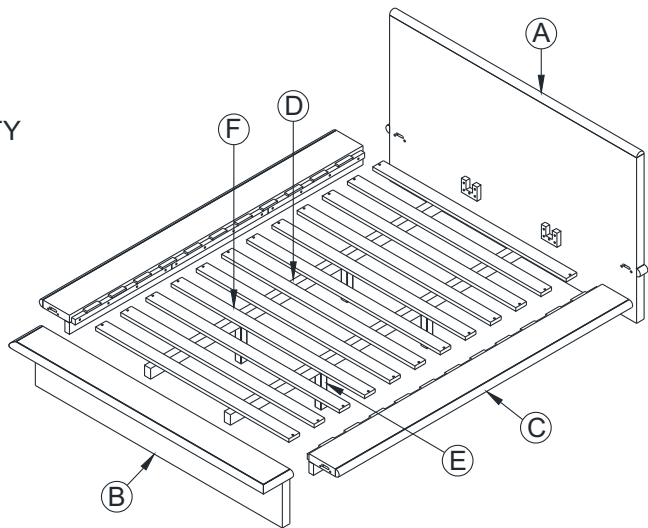

STEP 1

Attach Rails (C) to Headboard (A) & Footboard (B) using Allen Wrench (J), Nut M8 x 12 mm (I), Halfmoon Washer (H), Bolt M8 x 100 mm (G) clockwise to tighten as shown below.

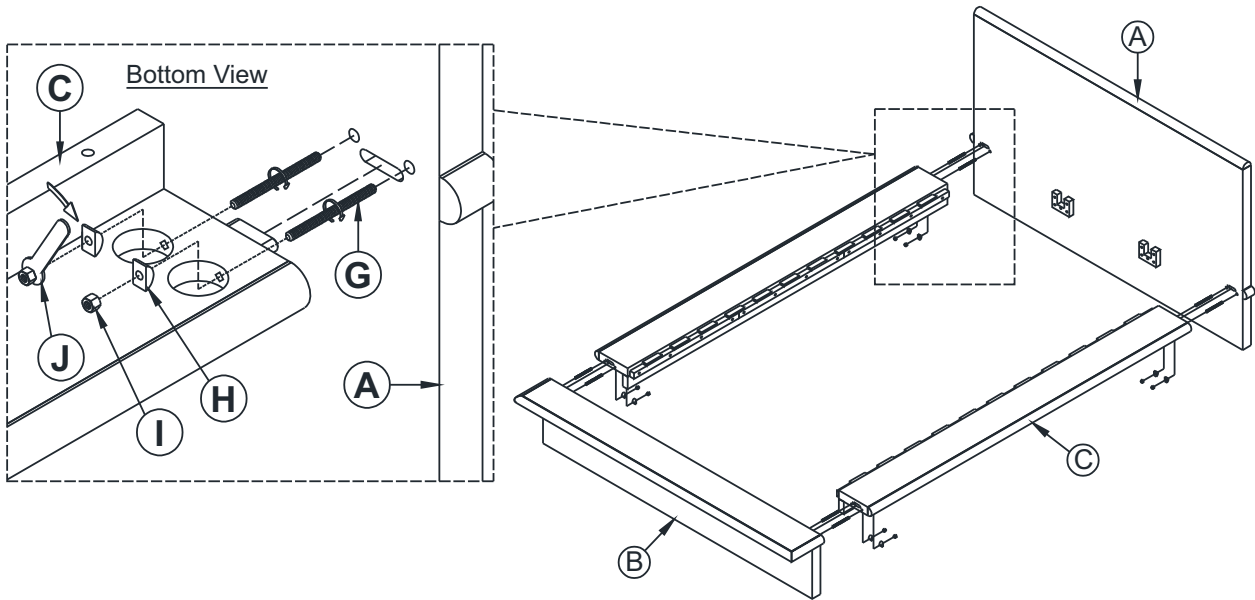

STEP 2

Attach Center Support (D) to Headboard (A) & Footboard (B) and Attach Center Legs (E) to Center Support (D) clockwise to tighten as shown below.

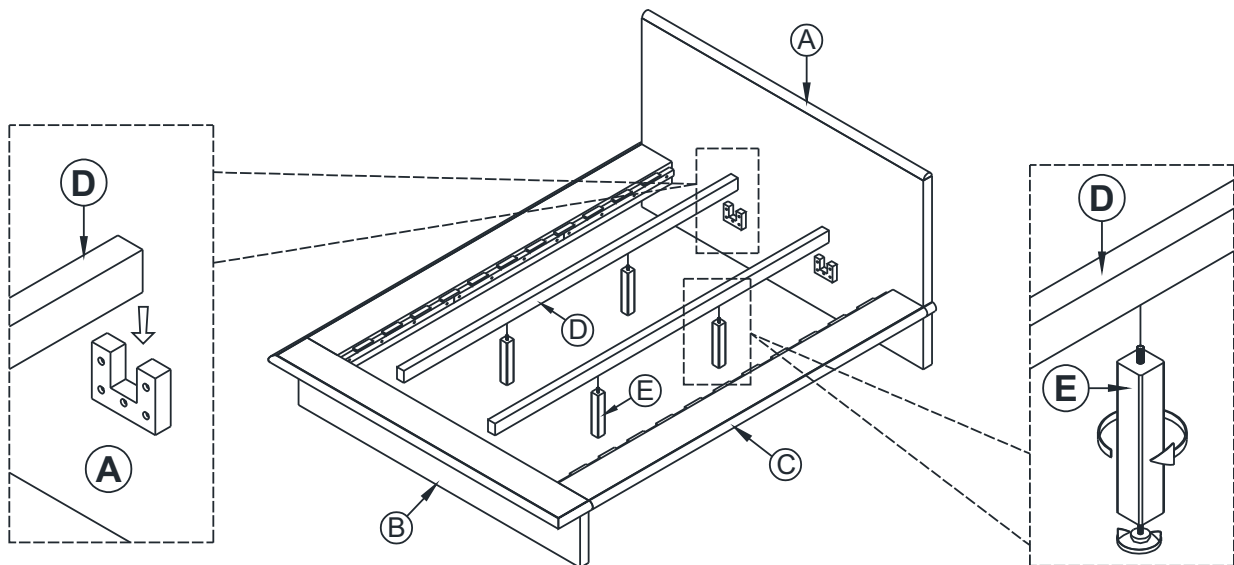

STEP 3

Attach Slats (F) to Side Rails (C) using Screw Driver (L), Screw JF 8 x 1" (K) as shown below.

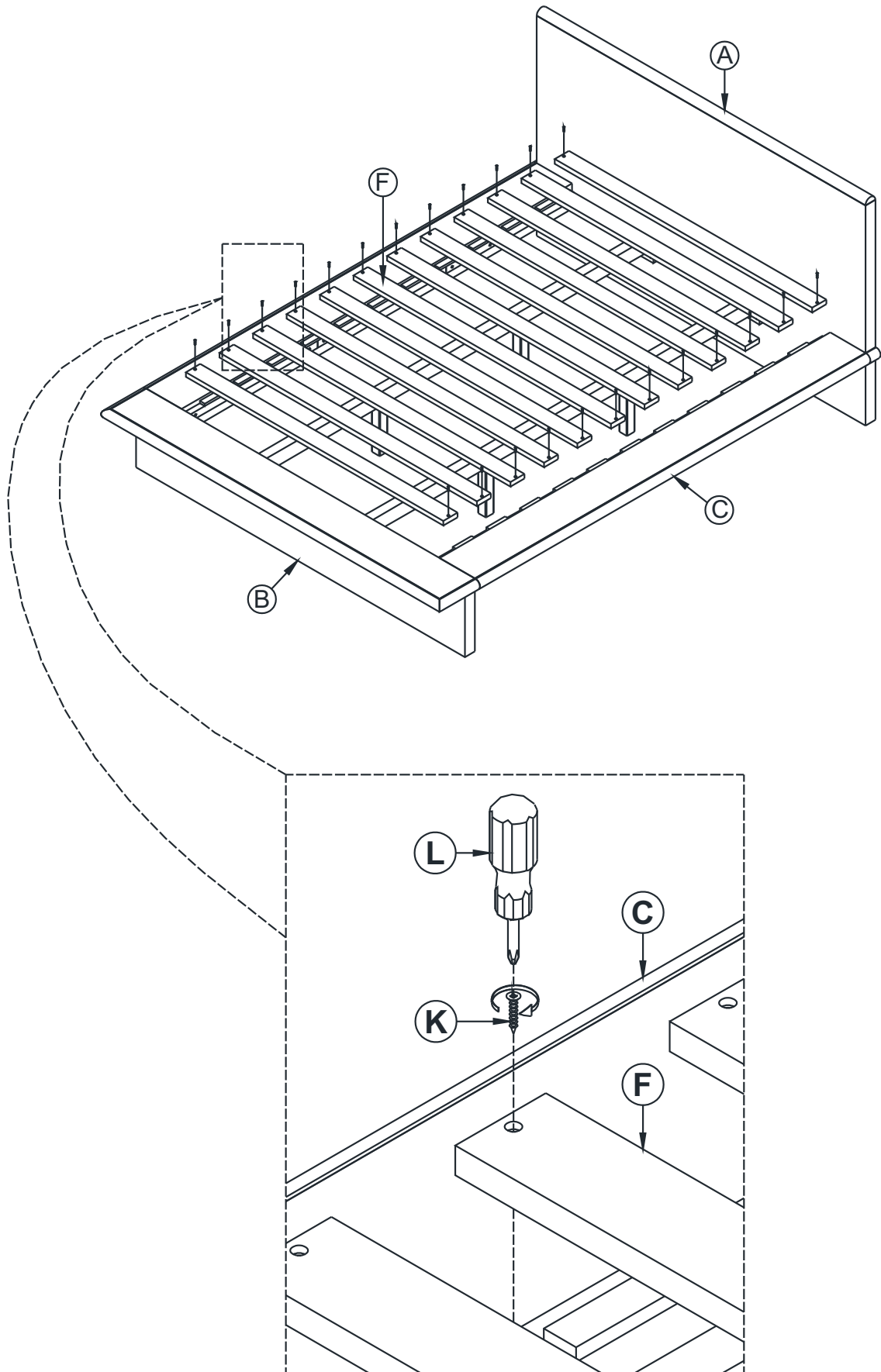

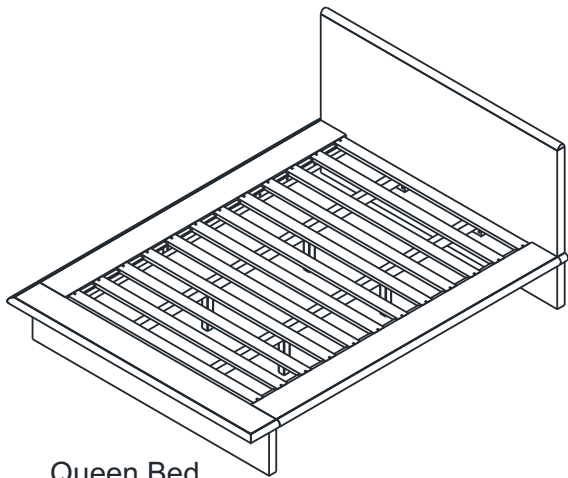

Queen Bed

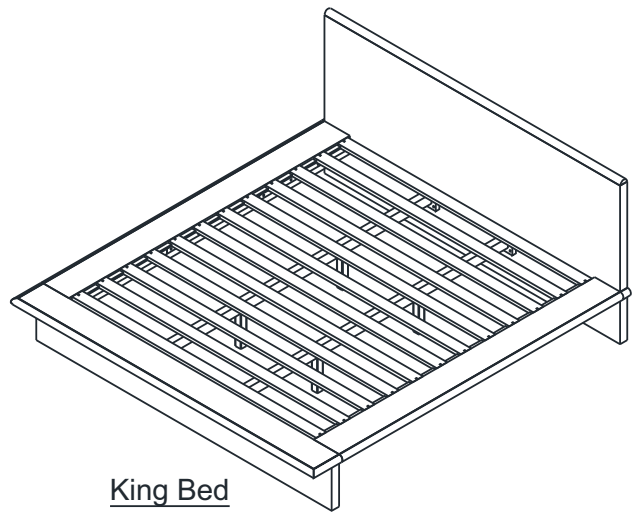

King Bed

Congratulations

Assembly complete, Your Queen Bed Or King Bed is ready to use.

(* Caution : DO NOT OVERTIGHTEN

In any correspondence regarding this product, please include the complete Butler identification number located on the underside of the product.

We hope this product will be a useful and decorative addition to your home for years to come.

Copyright© Butler Specialty Company, 08 / 24